



FISHING & INTERVENTION

**BI-DIRECTIONAL**  
**COILED TUBING**  
**ENERGIZER**

Manual D415

**THE LEGACY  
LIVES ON**

## Contents

### Logan Bi-Directional Coiled Tubing Energizer

Overview .....	2
Rig Up .....	2
Jarring .....	2
Rig Down .....	2
Dressing Area Maintenance.....	2
Disassembly .....	3
Inspection of Parts.....	3
Inspection of Critical Parts.....	4
Assembly .....	4
Filling the Energizer With Oil.....	5
Testing the Energizer .....	5
Figure 1: Energizer Tong and Vise Locations.....	6
Figure 2: Energizer Components.....	7
Figure 3: Energizer Seal Components .....	8
Figure 4: Disassembly.....	9
Table 1: Recommended Tightening Torque .....	9
Table 2: Oil Fill Volume and Acceptable Test Loads.....	10
Component Parts List .....	11
Energizer Test Form.....	12

#### LEGAL NOTICE

All references to Bowen® part numbers in this Price Book are used to identify interchangeable tools and parts. References to such tools and parts does not imply that Innovex is a licensee or is in any way affiliated with Bowen or National Oilwell Varco. Innovex does not sell, or offer to sell, National Oilwell Varco (Bowen) products.

"Bowen" is a registered trademark of National Oilwell Varco.

## OVERVIEW

The Logan Bi-Directional Coiled Tubing Energizer is designed to be operated with the matching Logan Bi-Directional Coiled Tubing Jar. The Energizer's function is to supply acceleration to the weight bar and the upper portion of the Jar during the Jar free stroke.

The Coiled Tubing Energizer is capable of applying up only, down only or up and down acceleration in a straight pull or push operation with splines that are engaged at all times. It can also be dressed to accelerate only up or only down.

The Logan Bi-Directional Coiled Tubing Energizer is essentially a hydraulic fluid spring which stores energy when a push or pull load is applied to the running string. When the energy is released by the free stroke of the Jar, the weight bar and Jar accelerates until a blow of high impact is struck. The short length of the Energizer makes it ideal for coiled tubing operations.

Logan Bi-Directional Coiled Tubing Energizers are hydrostatically pressure balanced and can operate at any depth. They can be dressed with special packing to withstand temperatures above 350°F. They are constructed of stainless steel for added strength and corrosion resistance.

This Energizer is simple to assemble and its unique design allows for easy, dependable operation.

The Energizer effectively accelerates the weight bar and the upper portion of the Jar with any push or pull load up to the maximum recommended load.

Since the Energizer's independent internal chambers are sealed at both ends, the operating oil cannot escape and well fluids cannot enter the chambers. The operating oil constantly lubricates the internal working parts promoting long wear life of the Energizer.

The comparatively large ID (Inside Diameter) of the Coiled Tubing Energizer permits the use of drop balls for unlatching devices and accessories.

Prior to running any operation using the Coiled Tubing Energizer, it is necessary to configure the appropriate weight between the Coiled Tubing Energizer and Jar to achieve the best impact/impulse. The weight must be between the Jar and Energizer (no weight above the Energizer).

The lubricator must be of sufficient length to contain both the downhole fishing assembly and the fish.

***NOTE:** If the Energizer and/or weight are not run with the Jar due to a desire to keep the bottomhole assembly short, the effectiveness of the Jar will not be fully utilized.*

## RIG UP

All internal and external threaded connections are tightened to the recommended torque at the dressing facility prior to shipment.

Drift all the elements of the down hole fishing assembly with any drop balls which will be used.

Tong the Bi-Directional Coiled Tubing Energizer only on tool joint OD (Outside Diameter). Do not tong on the body joints. Doing so will damage the tool.

For the maximum effectiveness of Jar, the Bi-Directional Coiled Tubing Energizer should be installed in the string above the weight bar, which is attached to the top of the Logan Bi-Directional Coiled Tubing Jar.

The Logan Bi-Directional Coiled Tubing Energizer is always used in conjunction with a Logan Bi-Directional Coiled Tubing Jar.

In deviated and horizontal holes, the lack of available stretch in the running string below the kickoff point causes a great loss in the effectiveness of jarring blow. The Bi-Directional Coiled Tubing Energizer provides the means to store the required energy above the Jar and effectively offsets the loss of stretch in the running string. The Logan Bi-Directional Coiled Tubing Energizer also has an important secondary contribution, the hydraulic fluid in the Energizer cushions the shock of the running string, as it rebounds after each jarring stroke. This reduces shock-damage to the tool and running string.

## JARRING

The cycle life of the coiled tubing string should be considered when planning the jarring operation.

The Coiled Tubing Energizer is capable of applying up only, down only or up and down acceleration in a straight pull or push operation with splines that are engaged at all times.

## RIG DOWN

Remove the tool from the string and inspect for damage and oil leaks.

Prior to storage, the tool should be flushed out. Wash the tool joints and replace thread protectors before racking the tool.

## DRESSING AREA MAINTENANCE

### Overview

After field service, the Logan Bi-Directional Coiled Tubing Energizer should be disassembled, cleaned, inspected and redressed.

### Equipment Required

The following is a list of equipment that will be required to dress the Energizer:

1. A vise or equivalent device of a suitable size capable of clamping the tool horizontally and vertically.
2. Overhead crane with adequate capacity.

3. Non-marking friction tongs for outside diameters of body parts.
4. Lift straps suitable for lifting heavy parts during assembly and disassembly.
5. An inclined Coiled Tubing Jar Tester.
6. Packing set for the size tool being dressed.
7. T-Bar wrench, extensions, and sockets for the size tool being dressed.
8. Upper Pressure Body ID Setting Tool for the size tool being dressed.
9. Floater Removal Tool (to remove the Nut from the Upper Pressure Body) for the size tool being dressed.
10. Polypak Stretcher and Install Tool for the size tool being dressed.
11. 100 ml and 1000 ml graduated cylinder.
12. Filtering funnel with extension.
13. Stainless steel anti-seize grease.
14. Combination wrenches of suitable sizes for the Mandrel Extension.
15. Energizer Oil – Mobile DTE 24 ISO 32 Hydrocarbon Oil or equivalent.
16. Disassembly Sub for the size tool being dressed.
17. Clean sheet or rolled paper.

## DISASSEMBLY

**NOTE:** Correct placement of the vise and tong is required when breaking connections to prevent damage to the tool. For correct placement see Figure 1: Tong and Vise Locations on page 6.

**WARNING:** The Energizer could contain residual well pressure. Care should be taken when unscrewing connections to avoid bodily harm.

1. In a vise, break all external joints supporting the end of the Energizer to prevent bending. DO NOT fully unscrew the parts.

**CAUTION:** Do not clamp or tong over the thread area at any time to prevent galling of the connection.

2. Place the Energizer horizontally in a vise, gripping on the Upper Pressure Body. Remove the Top Sub.
3. Liberally apply stainless steel anti-seize grease to pin thread and 20° shoulder of Disassembly Sub. Install Disassembly Sub hand-tight with extension and socket. See Figure 4: Disassembly on page 9.

**WARNING:** The Energizer could contain residual well pressure. Care should be taken when unscrewing connections to avoid bodily harm.

4. Flip the assembly around and clamp on the Upper Pressure Body. Place an oil catch pan under the Upper and Lower Pressure Body connection. Slowly unscrew the Lower Pressure Body from Upper Pressure Body until any trapped pressure escapes or oil seeps thru the threads.

Do not completely unscrew the Lower Pressure Body.

**WARNING:** The Mandrel could rapidly stroke shut against the Spline Body when the residual pressure is released. Keep clear of this area.

5. Screw in the Lower Pressure Body about two (2) or three (3) turns.
6. Flip the assembly around and clamp on the Mandrel, supporting the extended end. On the Top Sub end, using the T-bar wrench, slowly loosen the Nut. Once pressure has been released, remove Disassembly Sub and lay it aside. Allow oil to drain.

**WARNING:** When the Nut disengages, the T-bar wrench could jump outward. Stand clear of the T-bar wrench.

7. Remove Upper Pressure Body. Using the Floater Removal Tool, remove the Nut from the bore of the Upper Pressure Body. Lay the parts aside.
8. With two (2) appropriately sized combination wrenches installed at 180° on the hex or flats of the Mandrel Extension, loosen and remove it. Lay the part aside.
9. Remove the Lower Pressure Body and lay the part aside.
10. Separate the Spline Body, Mandrel and Splines. Lay the parts aside.

The disassembly is now complete.

## INSPECTION OF PARTS

Non-Extrusion Rings are normally re-used and should not be removed unless they are damaged.

Inspect all seals as they are removed for unusual wear patterns. Noting seal wear can help pinpoint other areas of wear that could cause premature seal failure.

All parts should be cleaned prior to inspection. High-pressure wash all parts with soap and hot water inside and out. Rinse the soap off with hot or cold water, spraying from both ends. Blow dry (with air) the ID, OD, and threads. Place the dry, clean parts on a clean sheet of paper.

**NOTE:** Seals are to be replaced at re-dress when the tool is at a repair facility.

**CAUTION:** Magnetic particle inspection is strongly recommended for locating fatigue cracks that could lead to failure downhole. Parts with cracks must be replaced.

Inspect all parts for signs of damage on seal surfaces, splines, bores, bearing faces at each connection, and impact surfaces. Inspect all outside body parts for OD wear.

## INSPECTION OF CRITICAL PARTS

### Mandrel Extension

Examine the bump OD sealing surface of the Mandrel Extension for galling or pitting. If severe damage is noted, the part will have to be replaced or reworked by returning it to the manufacturing facility for repair.

### Splines

Damaged Splines should be replaced.

### Mandrel and Spline Body

Inspect spline grooves for damage. Buff spline grooves to remove damage.

**WARNING: Care should be taken when using power tools. Always wear protective eyewear and gloves to prevent metal particles from injuring the eyes and hands.**

## ASSEMBLY

### Preparation

All parts must be cleaned after Magnetic Particle Inspection. High-pressure wash all parts with soap and hot water inside and out. Rinse the soap off with hot or cold water, spraying from both ends. Blow dry (with air) the ID, OD, and threads. Place the dry, clean parts on a clean sheet of paper.

Prior to assembly, install all seals in their proper location by observing their location and direction as shown in Figure 3: Energizer Seal Components, on page 8. Some seals have special non-extrusion devices and care should be taken to assure their proper orientation.

**CAUTION: Only lint free cloths should be used while handling the tool.**

### Assembling the Energizer

1. Place the Lower Pressure Body vertically in a vise with the stencil groove towards the top.
2. Apply stainless steel anti-seize grease on the entire box OD, ID, and internal shoulder of the Mandrel, at the small end.

3. Ensure that the Splines do not have any sharp corners. Separate the Spline body into two halves.

**CAUTION: Ensure the Spline Body is a matched set. Parts are stenciled with set numbers.**

Place the Splines into the spline grooves of the Spline Body and freely apply stainless steel anti-seize grease on the entire ID of both halves. Place one half on a bench. Orient the Mandrel and Spline Body as shown in Figure 2: Energizer Components on page 7. Lay the Mandrel on the Spline Body half where the spline grooves of Mandrel line up with the Splines. Place the other half on the Mandrel aligning the Spline Body halves and press together. Grease the entire Spline Body Pin end, including threads and shoulder. Screw the Spline Body with Mandrel into the Lower Pressure Body hand-tight.

4. Move tool into pipe vise clamping onto the Spline Body with the split horizontal. Tighten Lower Pressure Body to Spline Body to specified torque. See Table 1: Recommended Tightening Torque, on page 9.
5. Loosen vise and move tool so vise is gripped onto tool joint OD of Mandrel. Ensure that it is possible to stroke the Lower Pressure Body and Spline Body by hand. (It may at first be difficult to stroke, but it should get easier after a few strokes.) If the tool will not stroke, disassemble the Spline Body and Mandrel from the Lower Pressure Body. Clean, inspect the sliding surfaces, remove any galls or burrs, and reassemble the parts. Retest the sliding of the Mandrel.
6. Open the Mandrel completely. Put the tool vertically into the bench vise with the Mandrel end down.

7. Wipe the Mandrel Extension with a lint free cloth to ensure it is clean. Insert the Mandrel Extension with the wrench flats or hex end at the top into the tool. Push down and rotate until it shoulders against the Mandrel. If unable to rotate by hand, use the combination wrench on the wrench flats or hex and rotate until seated.

8. Move the tool into the pipe vise, gripping the tool joint OD of the Mandrel. With two combination wrenches, at 180° apart on wrench flats or hex, tighten to the specified torque. See Table 1: Recommended Tightening Torque on page 9.

9. Move tool to bench vise and lightly clamp vertically around the Lower Pressure Body, not near the box threads, with Mandrel facing down in fully-open position.

10. In the open position, fill the lower (push) chamber with appropriate amount of Energizer oil. See Filling the Energizer with Oil on page 5.

11. Apply stainless steel anti-seize grease on entire pin end and shoulder of the Upper Pressure Body. Also apply stainless steel anti-seize grease to the ID seal area to just past the seal. Install the Upper Pressure Body, hand-tight.

12. Apply stainless steel anti-seize grease to the entire pin end and shoulder of the Top Sub. Install the Top Sub.

13. Push test the Energizer. (See Testing the Energizer on page 5.)

14. When push test is acceptable, leave the tool in the near fully closed position. Place the tool in vise vertically with Top Sub end up. Remove the Top Sub.

15. Fill the upper (pull) chamber with appropriate amount of Energizer oil. See Filling the Energizer with Oil on page 5.

16. Coat the ID threads, internal shoulder and OD Optiseal on the Nut with stainless steel anti-seize grease. Do not grease over the rubber seals. Coat the rubber seals with Energizer oil. Install the Nut into the Upper Pressure Body with the hex end up. Using the Nut Installation tool (T-Bar wrench, extension and socket) press down while turning in order to force the Nut into the seal bore of the Upper Pressure Body. Tighten (do not torque) until the Nut shoulders on the Mandrel Extension.
17. If needed, touch up Top Sub with stainless steel anti-seize grease and install into the Upper Pressure Body.
18. Pull test the Energizer. (See Testing the Energizer on page 5.)
19. After acceptable pull test, place the Energizer horizontally into the vise clamping onto the Mandrel Tool Joint OD. Remove Top Sub and tighten Nut to the specified torque. See Table 1: Recommended Tightening Torque on page 9.
20. If needed, touch up the Top Sub with stainless steel anti-seize grease and install into the Upper Pressure Body.
21. Reposition the tool in the vise and clamp onto the Spline Body with the split horizontal.

**NOTE:** Correct placement of the vise and tong is required when making up connections to prevent damage to the tool. For correct placement see Figure 1: Tong and Vise Locations on page 6.

22. Torque exterior joints with Non-marking friction tongs to the specified torque. See Table 1: Recommended Tightening Torque, on page 9.

### FILLING THE ENERGIZER WITH OIL

1. Pour needed amount of oil into the graduated cylinder. See Table 2: Oil Fill Volume and Acceptable Test Loads on page 10.
2. Place a filtered funnel extension inside the tool between outside of Mandrel Extension and inside of Body. Pour oil from the graduated cylinder into the tool thru the filtered funnel.

**CAUTION:** Care should be taken, not to allow the oil to overflow from the funnel. Overflow will cause the amount of oil to be incorrect and the tool will have to be disassembled, washed and reassembled.

### TESTING THE ENERGIZER

**NOTE:** Prior to testing the Energizer, make sure you have all the necessary technical data, test loads, and test sheets required to complete tests. The Logan Coiled Tubing Jar Tester is at a 15° incline.

#### Push Test

1. Install the proper Jar Tester Subs onto the Energizer and lift it into the Logan Coiled Tubing Jar Tester using an appropriate hoist.
2. Set push pressure on tester to the minimum. Start to push the Energizer closed and slowly increase pressure until tool is within 1/32" gap between the Spline Body and Mandrel. Hold load for approximately five (5) minutes. Verify the gap still exists, check for leaks and record push load. If there is a leak or no gap, disassemble and redress. If push load is within the test load range, the push test is complete. See notes on Table 2: Oil Fill Volume and Acceptable Test Loads on page 10. If push load was not reached, remove the Top Sub and Upper Pressure Body and add or remove oil as needed. Reassemble and retest.

**CAUTION:** Do not push more than the maximum test load shown in the notes on Table 2: Oil Fill Volume and Acceptable Test Loads on page 10.

#### Pull Test

1. Install the proper Jar Tester Subs onto the Energizer and lift it into the Logan Coiled Tubing Jar Tester using an appropriate hoist.
2. Set pull pressure on the tester to the minimum. Start to pull Energizer open and slowly increase pressure until tool is within 1/32" of being fully open as measured between Spline Body and Mandrel. Hold load for approximately five (5) minutes. Verify that the tool is not fully open. Check for leaks and record pull load. If there is a leak or the tool is fully open, disassemble and redress. If pull load is within the test load range, pull test is complete. See Table 2: Oil Fill Volume and Acceptable Test Loads on page 10. If pull load was not reached, remove Top Sub and Nut and add or remove oil as needed. Reassemble and retest.

**CAUTION:** Do not pull more than the maximum test load shown in Table 2: Oil Fill Volume and Acceptable Test Loads on page 10.

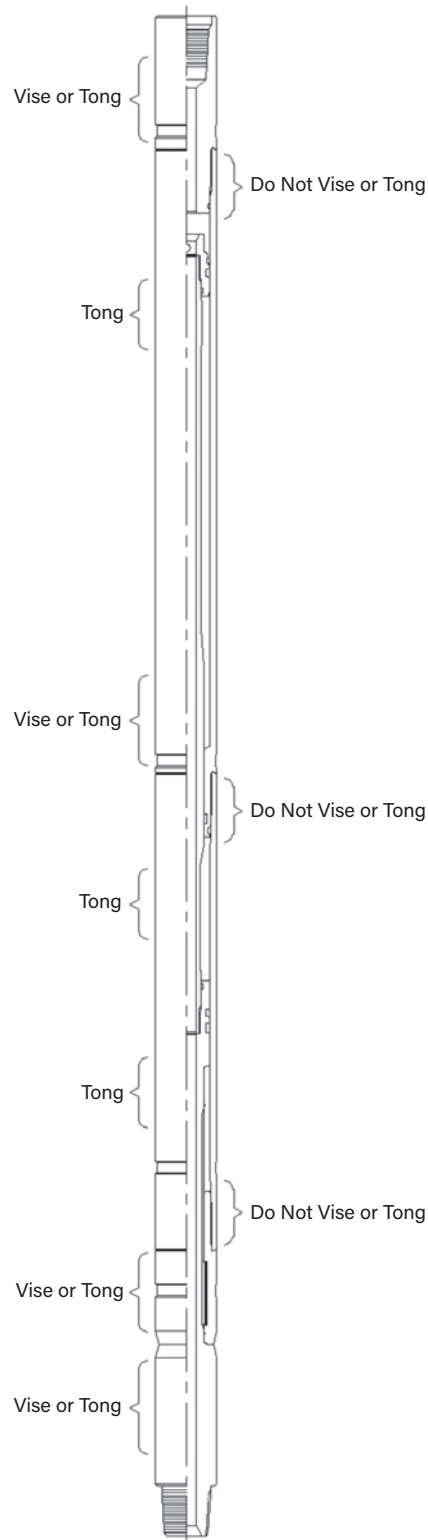

**Figure 1:**  
**Energizer Tong and Vise Locations**  
**for Applying Make-up and Break-out Torque**

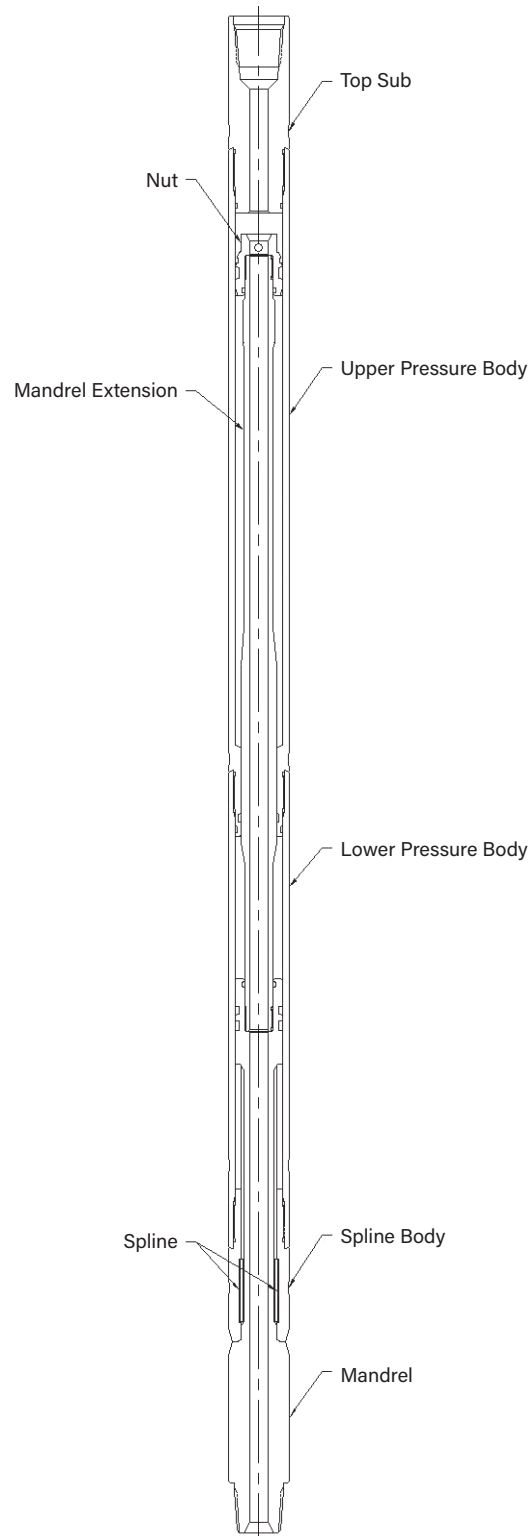

**Figure 2:**  
**Energizer Components**

*Innovex reserves the right to change or discontinue designs without notice.*



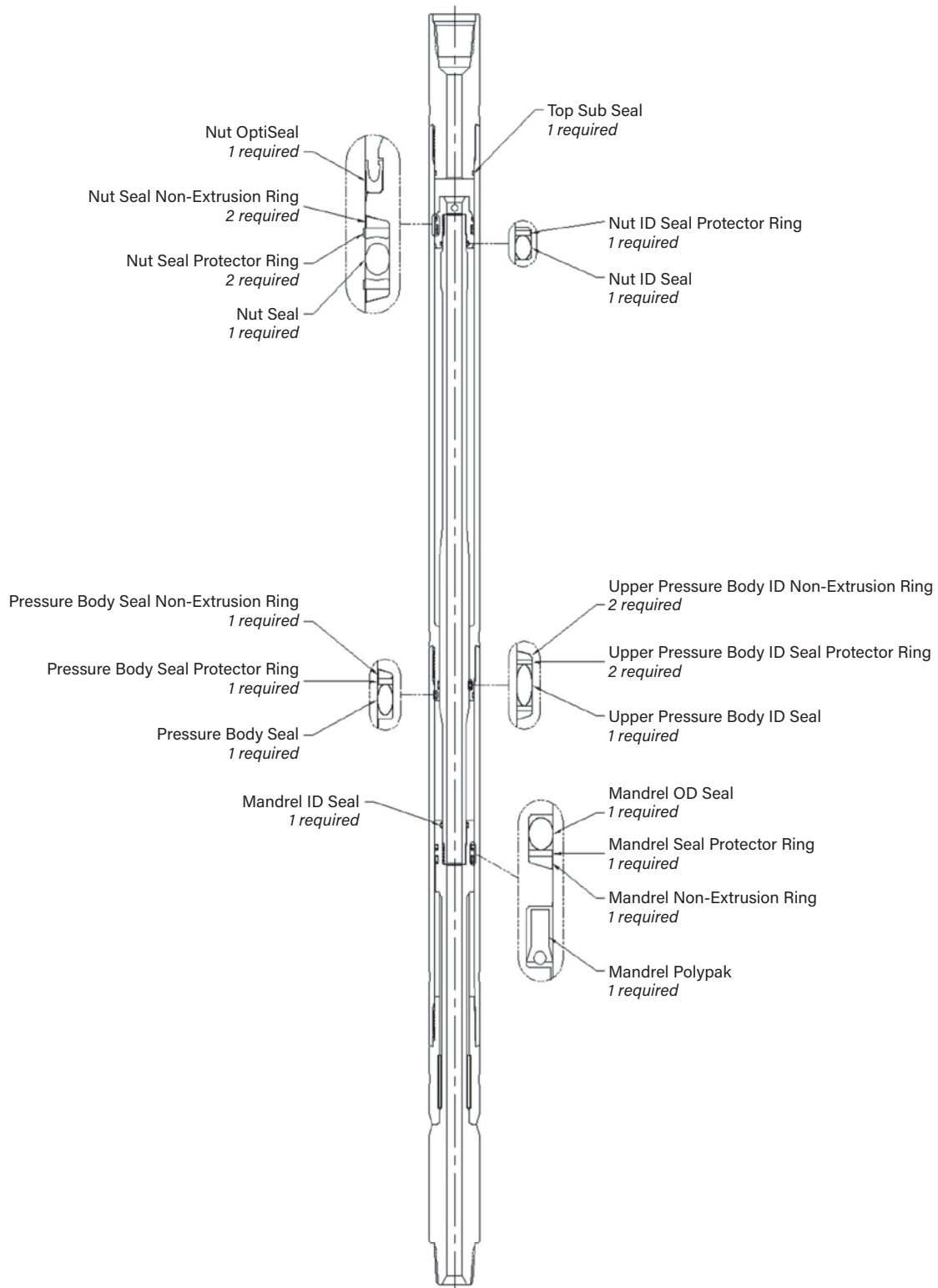

**Figure 3:**  
**Energizer Seal Components**

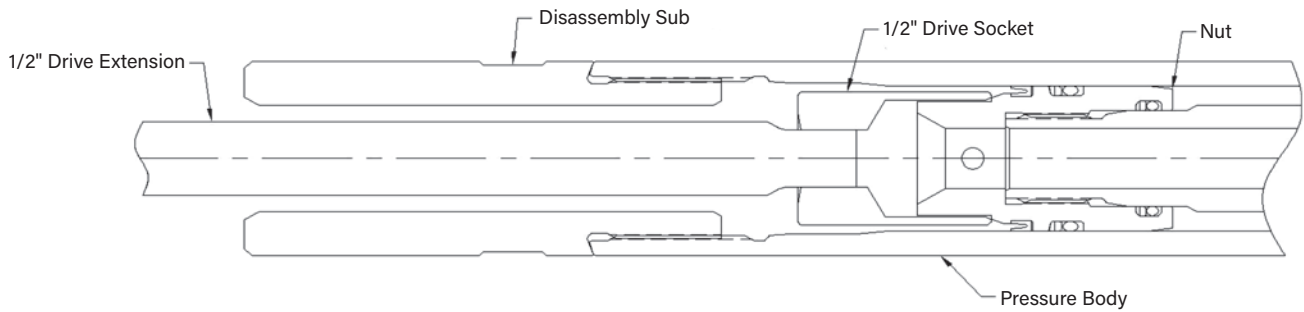

**Figure 4**  
**Disassembly**

**TABLE 1: RECOMMENDED TIGHTENING TORQUE**

<b>Tool OD size (in)</b>	<b>Outer Body Torque (ft-lb)</b>	<b>Mandrel Extension Torque (ft-lb)</b>	<b>Nut Torque (ft-lb)</b>
1-11/16	250	75	50
2-1/8	350	100	75
2-7/8	500	150	100

**TABLE 2: OIL FILL VOLUME & ACCEPTABLE TEST LOADS**

**1-11/16" OD Energizer**

Tool Downhole Temperature (°F)	Pull Chamber Initial Fill Volume (ml)	Pull Load to Open Tool in Jar Tester (lb)	Push Chamber Initial Fill Volume (ml)
100	113	9,970	79
200	110	5,770	79
300	107	3,070	79
400	106	1,700	79
500	105	1,140	79
600	104	900	79

Notes:

1. Chart is based on oil fill temperature of 60° to 90° F.
2. Adjust Pull Chamber fill volume to obtain loads shown in chart.
3. Pull load to open tolerance is -1,000 lb +1,500 lb
4. Adjust Push Chamber fill volume to obtain 1,500 lb -1,000 lb +2,000 lb to close the tool in Jar Tester.

**2-1/8" OD Energizer**

Tool Downhole Temperature (°F)	Pull Chamber Initial Fill Volume (ml)	Pull Load to Open Tool in Jar Tester (lb)	Push Chamber Initial Fill Volume (ml)
100	461	22,000	166
150	454	16,500	166
200	446	11,000	166
250	441	7,550	166
300	436	4,100	166
350	433	2,350	166
400	429	600	166
500	426	0	166
600	424	0	166

Notes:

1. Chart is based on oil fill temperature of 60° to 90° F.
2. Adjust Pull Chamber fill volume to obtain loads shown in chart.
3. Pull load to open tolerance is -2,000 lb +2,000 lb
4. Adjust Push Chamber fill volume to obtain 2,500 lb -1,000 lb +2,500 lb to close the tool in Jar Tester.

**2-7/8" OD Energizer**

Tool Downhole Temperature (°F)	Pull Chamber Initial Fill Volume (ml)	Pull Load to Open Tool in Jar Tester (lb)	Push Chamber Initial Fill Volume (ml)
100	699	33,300	287
150	689	25,700	287
200	678	18,100	287
250	671	13,350	287
300	664	8,600	287
350	660	6,150	287
400	655	3,700	287
450	653	2,700	287
500	651	1,700	287
600	648	900	287

Notes:

1. Chart is based on oil fill temperature of 60° to 90° F.
2. Adjust Pull Chamber fill volume to obtain loads shown in chart.
3. Pull load to open tolerance is -2,500 lb +3,000 lb
4. Adjust Push Chamber fill volume to obtain 3,500 lb -1,000 lb +3,500 lb to close the tool in Jar Tester.

OUTSIDE DIAMETER - INCHES		1-11/16 (1.708)	2-1/8 (2.156)	2-7/8 (2.906)
INSIDE DIAMETER - INCHES		17/32 (.530)	21/32 (.656)	29/32 (.906)
CONNECTION SIZE (BOX UP)		1" AMMT	1-1/2 AMMT	2-3/8 PAC
CONNECTION SIZE (PIN DOWN)		1" AMMT	1-1/2 AMMT	2-3/8 PAC
<b>COMPLETE ASSEMBLY</b>	Logan Part No.	<b>617-169</b>	<b>617-213</b>	<b>617-288</b>
<b>COMPONENT PARTS</b>				
<b>TOP SUB</b>	Logan Part No.	CC1000	CC1002	CC1004
<b>TOP SUB SEAL</b>	Logan Part No.	568122	568128	568226
<b>UPPER PRESSURE BODY</b>	Logan Part No.	CD2000	CD2002	CD2004
<b>UPPER PRESSURE BODY OD NON-EXTRUSION RING</b>	Logan Part No.	CC14000	CC14002	CC14004
<b>UPPER PRESSURE BODY OD SEAL PROTECTOR RING</b>	Logan Part No.	8-025	8-128	8-226
<b>UPPER PRESSURE BODY OD SEAL</b>	Logan Part No.	568025	568128	568226
<b>UPPER PRESSURE BODY ID NON-EXTRUSION RING</b>	Logan Part No.	CD4000	CD4002	CD4004
	No. Req'd	2	2	2
<b>UPPER PRESSURE BODY ID SEAL PROTECTOR RING</b>	Logan Part No.	8-120	8-217	8-223
	No. Req'd	2	2	2
<b>UPPER PRESSURE BODY ID SEAL</b>	Logan Part No.	568120	568216	568224
<b>LOWER PRESSURE BODY</b>	Logan Part No.	CD3000	CD3002	CD3004
<b>SPLINE BODY</b>	Logan Part No.	CD5000	CC5002	CC5004
<b>MANDREL</b>	Logan Part No.	CD6000	CD6002	CD6004
<b>MANDREL ID SEAL</b>	Logan Part No.	568118	568120	568220
<b>MANDREL OD NON-EXTRUSION RING</b>	Logan Part No.	CC15000	CC15002	CC15004
<b>MANDREL OD SEAL PROTECTOR RING</b>	Logan Part No.	8-121	8-221	8-327
<b>MANDREL OD SEAL</b>	Logan Part No.	568914	568221	568327
<b>MANDREL OD POLYPAK</b>	Logan Part No.	BD209-11	BD209-13	BD209-12
<b>MANDREL EXTENSION</b>	Logan Part No.	CD7000	CD7002	CD7004
<b>NUT</b>	Logan Part No.	CD8000	CC8002	CC8004
<b>NUT ID SEAL PROTECTOR RING</b>	Logan Part No.	8-118	8-120	8-220
<b>NUT ID SEAL</b>	Logan Part No.	568118	568120	568220
<b>NUT OD NON-EXTRUSION RING</b>	Logan Part No.	CC15000	CC15002	CC15004
	No. Req'd	2	2	2
<b>NUT OD SEAL PROTECTOR RING</b>	Logan Part No.	8-121	8-221	8-327
	No. Req'd	2	2	2
<b>NUT OD SEAL</b>	Logan Part No.	568914	568120	568327
<b>NUT OD OPTISEAL</b>	Logan Part No.	CC19000-001	CC19002-001	CC19004-001
<b>SPLINE</b>	Logan Part No.	CC12000	CC12002	CC12004
	No. Req'd	2	2	4
<b>REDRESS KITS</b>				
<b>REDRESS KIT</b>	Logan Part No.	CD10000	CD10002	CD10004
Consists of:				
<b>UPPER PRESSURE BODY</b>	Logan Part No.	CC14000	CC14002	CC14004
<b>OD NON-EXTRUSION RING</b>	No. Req'd	1	1	1
<b>NUT &amp; MANDREL OD NON-EXTRUSION RING</b>	Logan Part No.	CC15000	CC15002	CC15004
	No. Req'd	3	3	3
<b>UPPER PRESSURE BODY</b>	Logan Part No.	CD4000	CD4002	CD4004
<b>ID NON-EXTRUSION RING</b>	No. Req'd	2	2	2
<b>SEAL KIT</b>	Logan Part No.	CD9000	CD9002	CD9004
	No. Req'd	1	1	1
<b>SPLINE</b>	Logan Part No.	CC12000	CC12002	CC12004
	No. Req'd	2	2	4
<b>REQUIRED ACCESSORIES</b>				
<b>COMBINATION WRENCH SIZE FOR MANDREL EXTENSION - INCHES</b>		13/16	1	1-3/8
	No. Req'd	2	2	2
<b>SIX-POINT SOCKET SIZE FOR NUT - INCHES</b>		7/8	1-1/8	1-1/2
<b>FLOATER REMOVAL TOOL*</b>	Logan Part No.	CC18000	CC18002	CC18004
<b>POLYPAK STRETCHER</b>	Logan Part No.	CD11000	CD11002	CD11004
<b>POLYPAK INSTALLATION TOOL</b>	Logan Part No.	CD12000	CD12002	CD12004
<b>UPPER PRESSURE BODY SETTING TOOL</b>	Logan Part No.	CD13000	CD13002	CD13004
<b>SAFETY SUB</b>	Logan Part No.	CD15000	CD15002	CD15004

\* Used for removing Nut from Upper Pressure Body





## NORTH AMERICA

### CORPORATE HEADQUARTERS

4310 North Sam  
Houston Parkway East  
Houston, TX 77032  
T: +1 346 398 0000  
sales@innovex-inc.com

### EAST TEXAS & LOUISIANA

1138 West Harrison Rd  
Longview, TX 75604  
T: +1 903 759 2800

2212 Highway 662 N  
Building C  
Amelia LA 70340  
T: +1 985 412 4980

### SOUTH TEXAS

5746 Leopard Street  
Corpus Christi, TX  
78408  
T: +1 361 452 2771

178 Oil Road  
Pleasanton, TX 78064  
T: +1 830 401 5887

### FISHING TOOLS

1519 S. Flournoy Rd  
Alice, TX 78332  
T: +1 361 396 0139

10938 Lucerne St  
Houston, TX 77016  
T: +1 281 219 6613

601 McDonald St  
Odessa, TX 79761  
T: +1 432 580 7414

1034 Forum Dr  
Broussard, LA 70518  
T: +1 337 492 5228

118 Common Court  
Houma, LA 70360  
T: +1 985 868 7333

2415 2nd Ave West  
Williston, ND 58801  
T: +1 701 572 0565

1294 South 1500 East  
Vernal, UT 84078  
T: +1 435 781 2856

### MIDCONTINENT

17712 W. Hwy 33  
Cashion, OK 73016  
T: +1 832 775 9140

2709 S. Ann Arbor Ave  
Oklahoma City, OK  
73128  
T: +1 405 491 2658

### PERMIAN BASIN

9513 W. County Rd 143  
Midland, TX 79706  
T: +1 979 314 3764

3111 W. 114th  
Levelland, TX 79336  
T: +1 806 215 7960

5910 S. County Rd 1270  
Midland, TX 79706  
T: +1 432 999 4013

651 McDonald Street  
Odessa, TX 79761  
T: +1 918 445 0588

### NORTHWEST

1848 Old Route 33  
Weston, WV 26452  
T: +1 304 841 0821

109 N. Madison Ave  
Grove City, PA 161257  
T: +1 724 605 1397

### ROCKIES | BAKKEN

13 Town & County Ln  
Williston, ND 58802  
T: +1 701 353 3334

480 Basher Dr  
Berthoud, CO 80513  
T: +1 720 552 9982

600 17th St, Suite  
2800 South Tower  
Denver, CO 80202  
T: +1 601 218 3728

### CANADA

4116-51 Avenue NW  
Edmonton, Alberta,  
Canada T6E 5V8  
T: +1 780 433 9957  
F: +1 780 472 2351

## LATIN AMERICA

### MEXICO

Mexico City, Mexico  
T: +52 55 5545 8111  
M: +52 1 55 2668 1760

Carretera Villahermosa –  
Cárdenas Km 5.5, Bodega  
M1L6B2, Interior Parque  
Logístico Industrial Tabasco,  
Ria. Anacleto Canabal  
4ta sección, Centro Tabasco,  
86287  
T: +52 9933 168887

### COLOMBIA

Kra 100 No. 25 C 11 Bd 7,  
Centro empresarial Omega  
Bogota, Columbia CP 110911  
T: +57 1 756 1920

### ARGENTINA

Espana 337 Cipolletti,  
Argentina  
Luis Beltran 367 Neuquen,  
Argentina  
T: +54 911 5643 4197

## MIDDLE EAST & ASIA

### UNITED ARAB EMIRATES

Office 2109, Jumeirah  
Bay X3 Tower  
Cluster X, Jumeirah Lake  
Towers, Dubai, UAE  
PO BOX 333648  
T: +971 4 454 8616

### SAUDI ARABIA

7958 Abu Al Husan Al  
Zahrawy St  
Al Khalidiyah Ash Shamaliyah,  
Dammam 32231 3257  
T: +966 13 814 6662

### SULTANATE OF OMAN

Warehouse # 160Z, BBH  
Logistics City  
Rusayl Industrial Area, Muscat,  
Sultanate of Oman  
T: +968 225070199

## EUROPE, CASPIAN & AFRICA

### SCOTLAND

1 Minto Place  
Altens Industrial Estate,  
Aberdeen, Scotland  
AB12 3SN  
T: +44 1224 659 000